



Art. 021-0908-000

Air-operated industrial oil pump Mod. 908 flanged
Ratio=8:1 double-acting Delivery capacity 40 l/min
For wall-fixing or fixed positions.
Polyurethane seals

Art. 021-0908-094

Air-operated industrial oil pump Mod. 908 flanged
Ratio=8:1 double-acting Delivery capacity 40 l/min
For drums of 180-220 l
Polyurethane seals

Art. 021-0908-125

Air-operated industrial oil pump Mod. 908 flanged
Ratio=8:1 double-acting Delivery capacity 40 l/min
For tanks of 750-1500 l
Polyurethane seals



021-0908-000	23,000	0,110	1
021-0908-094	25,900	0,150	1
021-0908-125	27,600	0,180	1

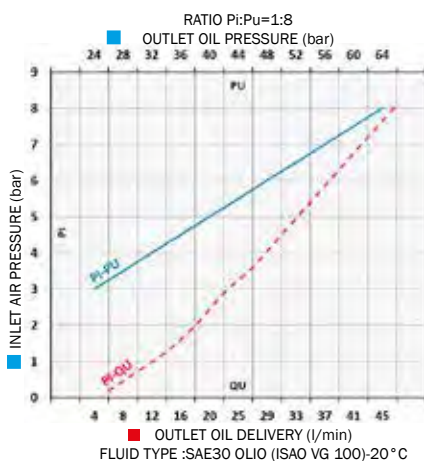
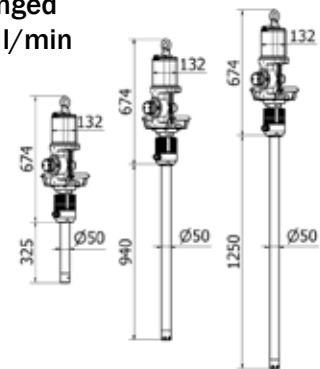

Technical Data	021-0908-000	021-0908-094	021-0908-125
Compression ratio	8:1	8:1	8:1
Working pressure	bar	8	8
Air consumption at 8 bar	m ³ /min	1,75	1,75
Air inlet connection	BSP	F 1/2" G	F 1/2" G
Fluid outlet connection	BSP	M 3/4" G	M 3/4" G
Fluid delivery cap. at 8 bar	l/min	40	40
Noise	dB	80	80
Shank diameter	mm	50	50
Shank length	mm	Modular F 1"	940
For drums	l	-	180-220
			750-1500

These pumps are advised for the transfer of low-high viscosity oil and similar fluids for medium-long distances. The delivery capacity of a pump varies according to particular applications and combinations. The operating pressure may vary between a minimum of 3 bar and a maximum of 8 bar.

The double-acting guarantees the delivery of a continuous and constant flow, suitable for installations on distribution facilities. To optimize the performance and the time-life of the air-operated pumps we advise to use filtered and lubricated air.