



AIR-OPERATED GREASE PUMPS Mod. 660

COMPRESSION RATIO = 60:1

DELIVERY = 1600 g/min



Art. 010-1000-000

Air-operated grease pump R=60:1 Mod. 660

For standard drums **12-16 kg**

(shank length 410 mm)

Polyurethane seals

Art. 010-1005-000

Air-operated grease pump R=60:1 Mod. 660

For standard drums **18-30 kg**

(shank length 480 mm)

Polyurethane seals

Art. 010-1010-000

Air-operated grease pump R=60:1 Mod. 660

For standard drums **50-60 kg**

(shank length 750 mm)

Polyurethane seals

Art. 010-1015-000

Air-operated grease pump R=60:1 Mod. 660

For standard drums **180-220 kg**

(shank length 950 mm)

Polyurethane seals

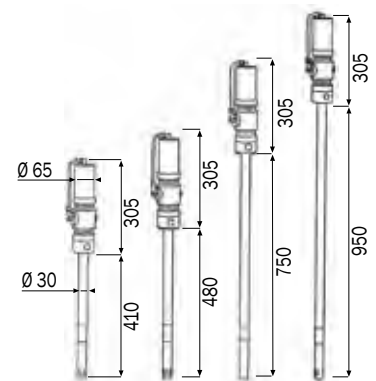

Art.	Weight (Kg)	Volume (m³)	Quantity (No.)
010-1000-000	4,980	0,010	1
010-1005-000	4,900	0,010	1
010-1010-000	6,000	0,013	1
010-1015-000	6,900	0,016	1

Technical data

	010-1000-000	010-1005-000	010-1010-000	010-1015-000
Compression ratio	60:1	60:1	60:1	60:1
Max pressure supply	bar	8	8	8
Medium air consumption	l/min	130	130	130
Air inlet connection	BSP	F 1/4" G	F 1/4" G	F 1/4" G
Grease outlet connection	BSP	M 1/4" G	M 1/4" G	M 1/4" G
Grease delivery capacity 8 barg/min		1600	1600	1600
Noise	dB	76	76	76
Shank diameter	mm	30	30	30
Shank length	mm	410	480	750
For drums with capacity of	kg	12-16	18-30	50-60
			180-220	

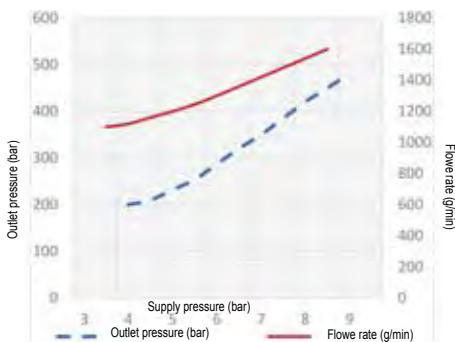

(GREASE NLGI 1 20° C)

These pumps are suitable for the supply at high pressure of greases with viscosity up to NLGI 2 at short and long distances. The operating pressure of the grease pumps hereby may vary between a minimum of 2.5 bar and a maximum of 8 bar. In order to optimize the efficiency and the life of our air-operated pumps, we recommend to use filtered and lubricated air.