

INDUSTRIAL AIR-OPERATED PUMPS FOR GREASE AND VISCOUS MATERIALS Mod. 1575 FLANGED

COMPRESSION RATIO=75:1 DELIVERY= 8000 g/min



Art. 011-1575-060

Air-operated industrial pump for grease R=75:1

Mod. 1575 flanged double-effect

For drums 18-30 kg and tanks (shank length 600 mm)

Polyurethane seals

For high viscosity grease and oils

Art. 011-1575-074

Air-operated industrial pump for grease R=75:1

Mod. 1575 flanged double-effect

For drums 50-60 kg (shank length 740 mm)

Polyurethane seals

For high viscosity grease and oils

Art. 011-1575-086

Air-operated industrial pump for grease R=75:1

Mod. 1575 flanged double-effect

For tanks (shank length 860 mm)

Polyurethane seals

For high viscosity grease and oils

Art. 011-1575-094

Air-operated industrial pump for grease R=75:1

Mod. 1575 flanged double-effect

For drums 180-220 kg (shank length 940 mm)

Polyurethane seals

For high viscosity grease and oils

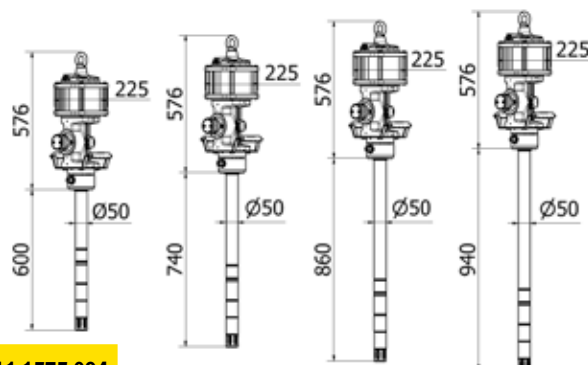

Art. No.	Price	Capacity (m³)	Quantity
011-1575-060	28,100	0,110	1
011-1575-074	30,500	0,150	1
011-1575-086	32,100	0,150	1
011-1575-094	33,000	0,150	1

Technical Data		011-1575-060	011-1575-074	011-1575-086	011-1575-094
Compression ratio		75:1	75:1	75:1	75:1
Max supply pressure	bar	8	8	8	8
Air consumption 8 bar	m³/min	2,90	2,90	2,90	2,90
Air inlet connection	BSP	F 1/2"G	F 1/2"G	F 1/2"G	F 1/2"G
Grease outlet connection	BSP	F 1/2"G	F 1/2"G	F 1/2"G	F 1/2"G
Grease delivery capacity 8 bar	g/min	8000	8000	8000	8000
Noise	dB	80	80	80	80
Shank diameter	mm	50	50	50	50
Shank length	mm	600	740	860	940
For drums with capacity of	kg	18-30	50-60	TANK	180-220

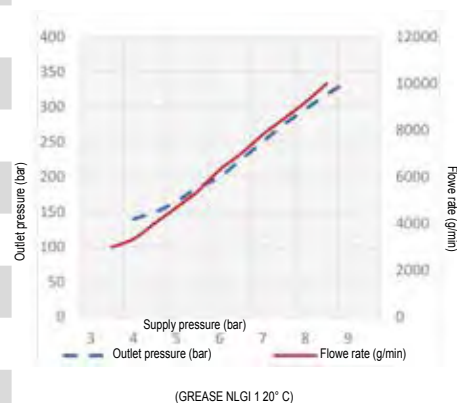

Suitable for high pressure transfer of high viscosity grease (maximum NLGI 3) over short and long distances. The double effect grants the supply of a constant and continuous flow. They are suitable for central distribution plants with multiple distribution points. The operating pressure of the pumps may vary between a minimum of 3 bar and a maximum of 8 bar. To optimize the efficiency and the life in time of our air operated pumps Meclube recommends to use filtered and lubricated air.